



Toll Free: 1-800-579-8088 Web: www.zinko.com

MODELS

ZR Series Heavy-Duty Hydraulic Cylinders

Operation & Maintenance Manual

Important Receiving Instructions

Visually inspect all components for shipping damage. Shipping damage is NOT covered by warranty. If shipping damage is found, notify carrier at once. The carrier is responsible for all repairs and replacement costs during product shipping.

Safety Information

Read and follow all **instructions, warnings, cautions** and carefully. Follow all safety precautions to avoid personal injury or property damage during system operation. **ZINKO** is not responsible for damage or injury resulting from unsafe product use, lack of maintenance, or incorrect product and/or system operation. Contact **ZINKO** when in doubt as to the safety precautions and operations. Failure to comply with the following cautions and warnings could cause equipment damage and personal injury.

Caution Remarks Used In This Manual

DANGER is only used when your action or lack of action can cause serious injury or death.

WARNING indicates a potential danger that requires correct procedures or practices to avoid personal injury.

CAUTION is used to indicate correct operating maintenance procedures and practices to prevent damage to or destruction of equipment or other property.

Operator Responsibility

It is the operator's responsibility to read and understand all of the following safety statements:

WARNING

1. STAY CLEAR OF LOADS SUPPORTED BY HYDRAULICS. A cylinder, when used as a lifting load device, should never be used as a load holding device. After the load has been raised or lowered, it must always be blocked mechanically. Use only rigid pieces to hold loads. CAREFULLY select steel or wood blocks that are capable of supporting the load.
2. NEVER USE A HYDRAULIC CYLINDER AS A SHIM OR SPACER IN ANY LIFTING OR PRESSING APPLICATION.
3. DO NOT EXCEED EQUIPMENT RATINGS. Never attempt to lift a load weighing more than the capacity of the cylinder. Overloading causes equipment failure and possible personal injury. The cylinders are designed for a maximum pressure of 700 bar (10,000 psi). DO NOT CONNECT A JACK OR CYLINDER(S) TO A PUMP WITH A HIGHER PRESSURE RATING.
4. NEVER SET THE RELEASE VALVE TO A HIGHER PRESSURE THAN THE MAXIMUM RATED PRESSURE OF THE PUMP. Higher settings may result in equipment damage and/or personal injury.
5. The system operating pressure MUST NOT exceed the pressure rating of the lowest rated component in the system. Install pressure gauges in the system to monitor operating pressure - *it is a window to what is happening within the system.*
6. BE SURE SETUP IS STABLE BEFORE LIFTING LOAD. Cylinders should be placed on a flat surface that can support the load. Where applicable, use a cylinder base for added stability. DO NOT WELD OR OTHERWISE MODIFY THE CYLINDER TO ATTACH A BASE OR OTHER SUPPORT. Avoid situations where loads are not directly centered on the cylinder plunger. Off-center loads produce considerable strain on cylinders and plungers. In addition, the load may slip or fall causing potentially dangerous results. Distribute the load evenly across the entire saddle surface. ALWAYS USE A SADDLE TO PROTECT THE PLUNGER.
7. Wear the proper personal protective gear when operating hydraulic equipment.

Hydraulic Hoses

CAUTION Avoid damaging hydraulic hoses including sharp bends and kinks when routing hydraulic hoses. Using a bent or kinked hose will cause severe back-pressure. Sharp bends and kinks will internally damage the hose leading to premature hose failure.

1. DO NOT DROP HEAVY OBJECTS ON HOSE. A sharp impact may cause internal damage to hose wire strands. Applying pressure to a damaged hose may cause it to rupture.
2. DO NOT LIFT HYDRAULIC EQUIPMENT BY THE HOSE OR SWIVEL COUPLERS. Use the carrying handle or other means of safe transport.
3. KEEP HYDRAULIC EQUIPMENT AWAY FROM FLAMES AND HEAT. Excessive heat will soften packings and seals resulting in fluid leaks. Heat also weakens hose materials and packings. For optimum performance DO NOT expose equipment to a temperature of 65° (150° F) or higher. Protect hoses and cylinders from weld spatter.
4. DO NOT HANDLE PRESSURIZED HOSES. Escaping oil under pressure can penetrate the skin causing serious injury. If oil is injected under the skin, SEE A DOCTOR IMMEDIATELY.

Zinko Hydraulic Jack

Models: ZR Series Hydraulic Cylinders

⚠ DANGER To avoid personal injury KEEP HANDS AND FEET AWAY FROM CYLINDER AND WORK PIECE during operation. Only use hydraulic cylinders in a coupled system. Never use a cylinder with unconnected couplers. If the cylinders become extremely overloaded, components can fail catastrophically causing severe personal injury.

IMPORTANT: Hydraulic equipment MUST ONLY be serviced by a qualified hydraulic technician. For repair service, contact the authorized **ZINKO** service center in your area. To protect your warranty, use only certified hydraulic lift oil.

⚠ WARNING Immediately replace worn or damaged parts with genuine **ZINKO** parts. Standard grade parts may break causing personal injury or property damage. **ZINKO** parts are designed to fit properly and withstand high loads.

Installation

1. *Make hydraulic connections.* Use a pump with a release valve or a 3-way valve and one hose for single-acting cylinders.
 - a) Use a pump with a 4-way valve and two hoses for double-acting cylinders.
 - b) **IMPORTANT:** Double-acting cylinders must have both couplers connected. Fully hand-tighten all couplers. Loose couplers connected will block the flow of oil between the pump and the cylinder(s).
2. *Remove air from cylinder.*
 - a) Single-acting cylinders: Position the cylinders so that the plunger is pointed down and the cylinder is lower than the pump. Fully extend and retract the cylinder 2 or 3 times.
 - b) Double-acting cylinders: Lay the cylinder in its side and have the couplers facing up. Fully extend and retract the cylinder 2 or 3 times.

NOTE: Collar threads are rated for the full capacity of the cylinder when fully engaged in attachments. **The use of cylinder attachments or extensions reduces the cylinder capacity by at least 50%.**

Operation

Operate the hydraulic pump to advance and retract the cylinder. Some single-acting cylinders are spring-return. Double-acting cylinders are powered in both directions by the pump.

IMPORTANT: When cylinders are used with power set attachments or components, the maximum system pressure must be limited to half the rated pressure of 700 bar (5,000 psi).

Maintenance

1. Use only certified hydraulic lift oil with these cylinders. The use of any other oil may invalidate warranty.
2. Use dust caps when cylinders are disconnected from the hose. Keep the entire cylinder clean to prolong cylinder life.
3. Store cylinders upright to prevent seal distortion.

Troubleshooting

These cylinders should be repaired only by Authorized **ZINKO** Technical Service Centers. Single-acting are spring-loaded and require special disassembly techniques to prevent personal injury.

PROBLEM	POSSIBLE CAUSE
Cylinder Will Not Advance.	1) Pump release valve is open. 2) Coupler is not fully tightened. 3) Oil level in pump is low. 4) Pump malfunctioning. 5) Load is too heavy for cylinder.
Cylinder Advances Part Way.	1) Oil level in pump is low. 2) Coupler is not fully tightened. 3) Cylinder plunger is binding.
Cylinder Advances In Spurts.	1) Air in hydraulic system. 2) Cylinder plunger is binding.
Cylinder Advances Slower Than Normal.	1) Leaking connection. 2) Coupler is not fully tightened. 3) Pump malfunctioning.
Cylinder Advances But Will Not Hold.	1) Cylinder seals leaking. 2) Pump malfunctioning. 3) Leaking connection. 4) Incorrect system setup.
Cylinder Leaks Oil.	1) Worn or damaged seals. 2) Internal cylinder damage. 3) Loose connection.
Cylinder Will Not Retract, or Retracts Slower Than Normal.	1) Pump release valve is closed. 2) Coupler is not fully tightened. 3) Pump reservoir overfilled. 4) Narrow hose restricting flow. 5) Broken or weak retraction spring. 6) Cylinder damaged internally.

Zinko Hydraulic Jack

Models: ZR Series Parts Breakdown

REV 100307

Item #	Description
1	Thread Protector
2	*Wiper
3	Bearing Stop Ring
4	Bearing Sleeve
5	Saddle
6	*Stop Ring
7	Screw
8	*Washer
9	Plunger

Item #	Description
10	Seating Nut
11	Spring
12	Rod Bearing
13	*Washer
14	Bearing
15	*U-cup
16	C-ring
RP	Repair Kits (All *)

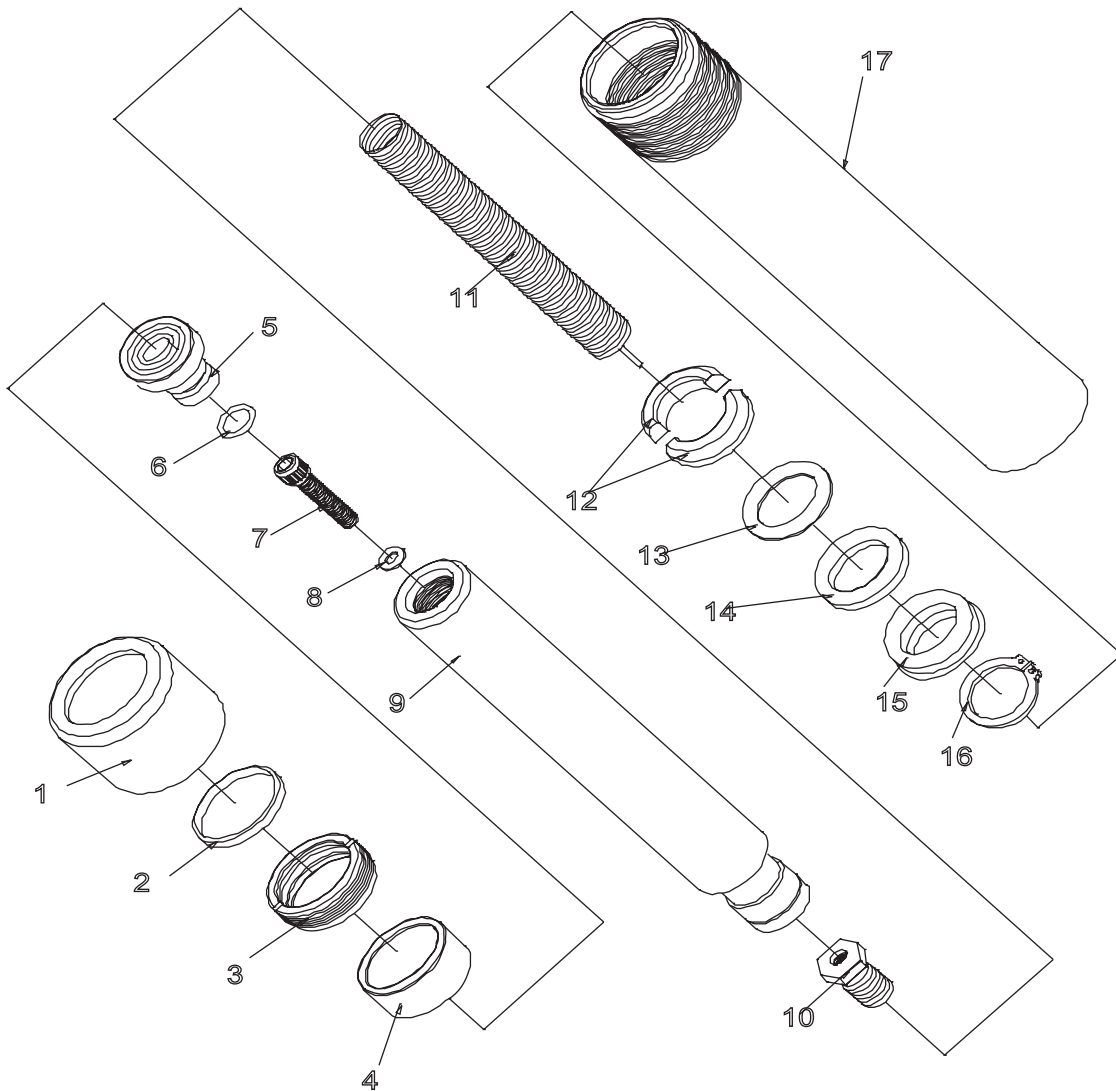

ZINKO HYDRAULIC JACK

PO Box 4903, Ontario, CA 91761

Toll Free: 1-800-579-8088

<http://www.zinko.com>

Phone: (909)989-9526

Fax: (909)989-1724